



All LPG work
 ZA La Boissonette - 07340 PEAUGRES
 Tel.+33 (0)4 75 32 53 01 - Fax +33 (0)4 75 32 52
 RCS ANNONAY 441 872 587 - APE 743 B

THIS DOCUMENT MAY NOT BE COPIED OR DISTRIBUTED WITHOUT PRIOR PERMISSION FROM FPS

N 0003

1/1

FLUIDES PETROLE SERVICES

DESCRIPTION OF FILL LIMITER KIT

OUTSIDE SAFETY ZONE

- A = Gauge dial
- B = 5 K Ω resistance transmitter
- C = Existing gauge flange
- E = Existing gauge with float
- F = DN50 PN50 filling valve
- G = Power-operated DN50 PN50 "ATEX & Fire safety" valve with emergency manual control
- H = ATEX II 2 GD IP67 electric actuator with emergency manual control
- I = Welded filling connector with plug

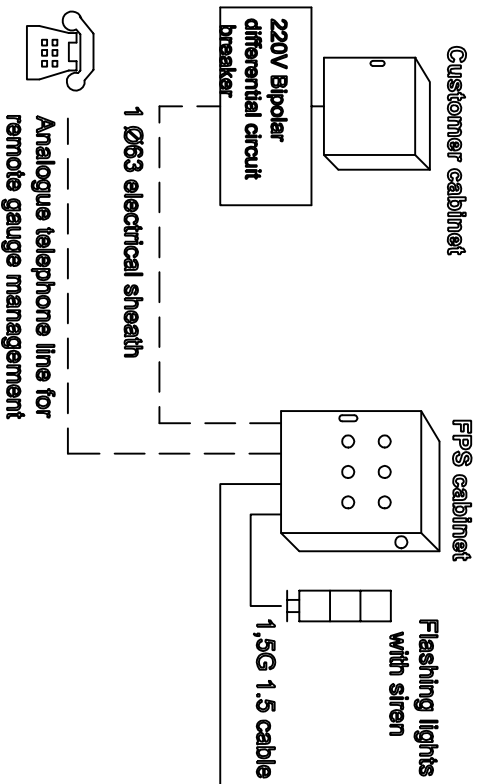

"ATEX" SAFETY ZONE

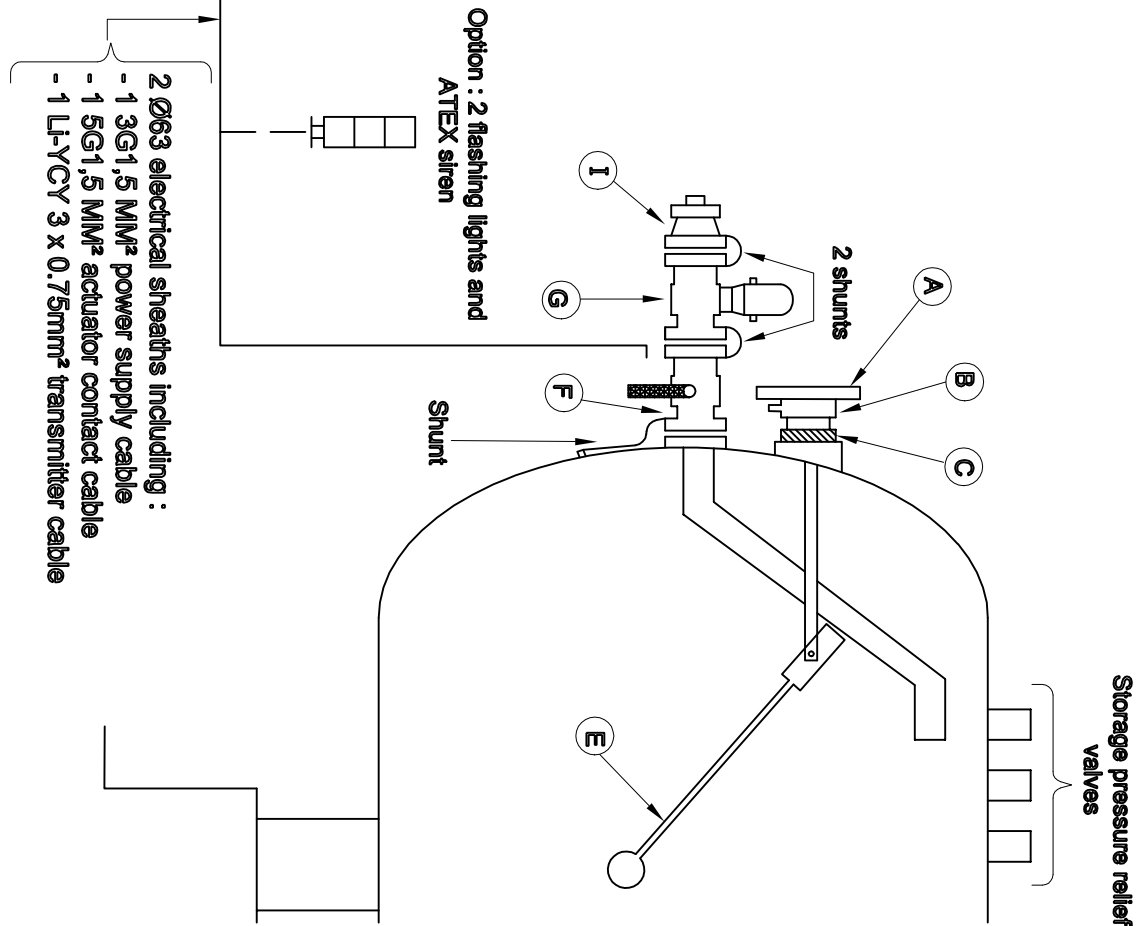

IMPORTANT : For all orders, note the exact characteristics of the flange on the existing gauge (C), including photos. Check the position of the filling valve handle.